

Amazing Pragmatical Energy Creation by Tesla's SPC.

2022/9/19,20,21

In 2012, Jean-Louis Naudin (France) had already accomplished **3818W** electrical power generation by input **1805W**.

Also author himself accomplished the very small verification of 26W output by 20W input as follows,

Now European has become suffered by terrible energy deficit, why the government with people has been neglecting his great contribution ??

[1]: The GEGENE : a Great Efficiency GENERator with a Tesla bifilar coil...

He accomplished $184 \times 20.75 \text{A} = \mathbf{3818W}$ output by **1805W** input by employing bifilar spiral coil (N. Tesla) = SPC in electromagnetically excited by Induction Heating Cooker().

---abstract by Suzuki.

The Quest For Overunity (c) JLN Labs 1997-2013 - by Jean-Louis Naudin

<http://www.jlnlab.com>

<http://jlnaudin.free.fr/gegene/gegene09en.htm>

created on december 28, 2012 - JLN Labs - last update february 1, 2013

Here is an interesting experiment about a high power electrical generator which is able to produce some KW. It uses the electronic controller of an induction cooker which can be purchased in any store for less than 80 €. The main specification of the GEGENE (Great Efficiency GENERator) is that it uses a BIFILAR PANCAKE COIL patented by Nikolas TESLA in 1894 in the patent N° 512,340.

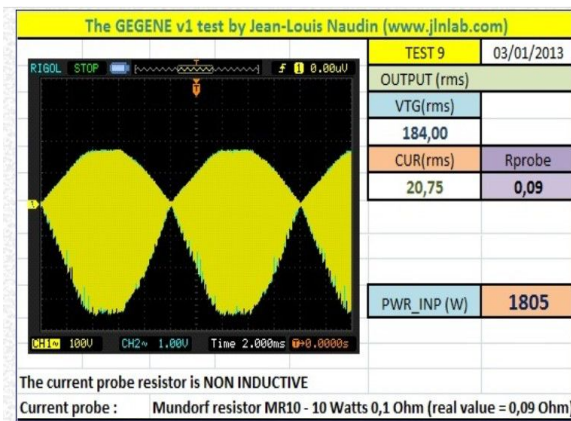

He accomplished $184 \times 20.75 = \mathbf{3818W}$ output by **1805W** input by employing bifilar spiral coil (N. Tesla)

The Principle of Induction Heating.

<https://www.tdk.com/ja/tech-mag/knowledge/015>

It was said that a current of about 60kHz should be extracted. That said, if we continue with the conventional method, there is a problem that the inverter switches themselves generate too much heat when the frequency is increased.

[2]: The Small Verification Test by Author(2022/9/19).

By DC power input of $\{0.11 \text{A} \times 185 \text{V} = 20.5 \text{W}\}$ → Light bulbs of $P_o = 26 \text{W}$ was accomplished. Author employs circuit resonance of L1-L2 SPC by tuning SW frequency 615kHz with the parallel $C_{//} = 2877 \text{pF}$. Everybody's desire is larger efficiency. At this time experience, larger input tends to rise efficiency?. Note Mr Naudin employed 1805W, while that of author is 20W.

$19 \text{W} < 525 \Omega > + 7 \text{W} < 1.43 \text{k} \Omega > : \mathbf{26 \text{W} < 384 \Omega >}$ LB_ I/O measurement <2022/9/19>

616kHz ($I_n = \text{min current}, C_{//} = 2877 \text{pF}$) $P_i = 0.110 \text{A} \times 185 \text{V} = 20.5 \text{W}$, $P_o = 26 \text{W}$ ($\eta = 1.27$)

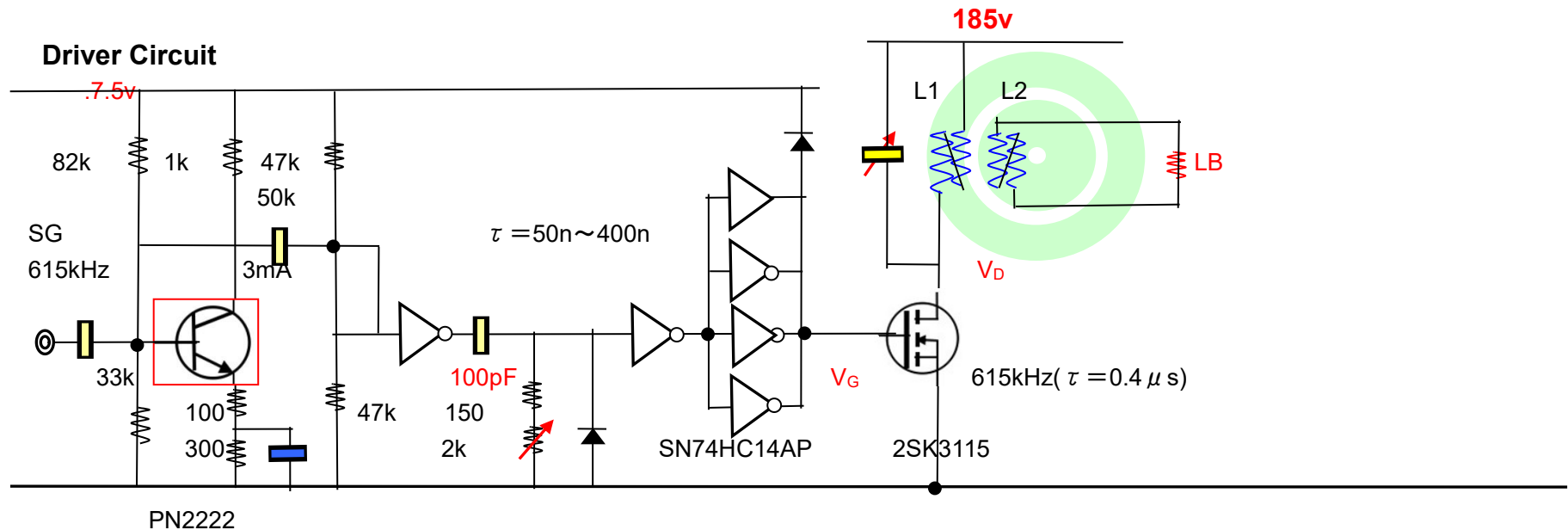
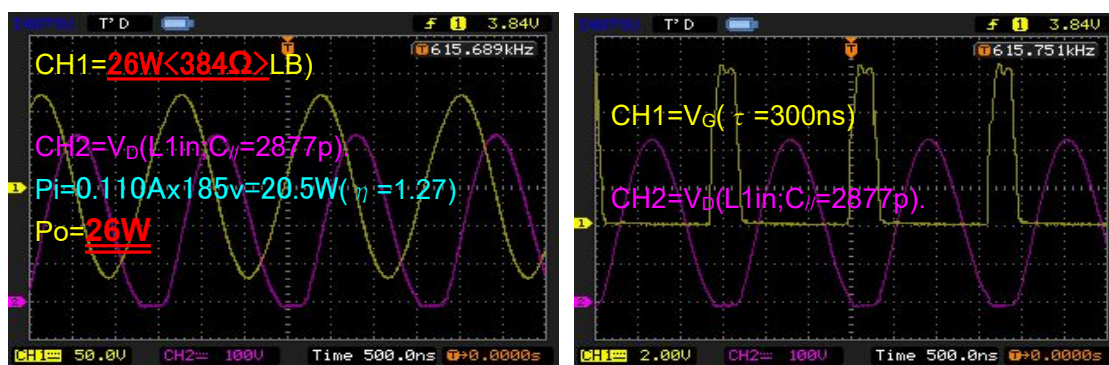

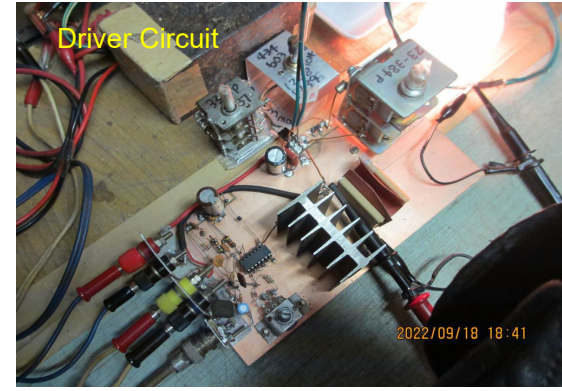
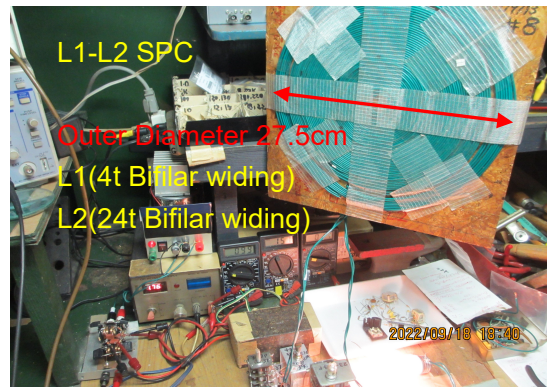
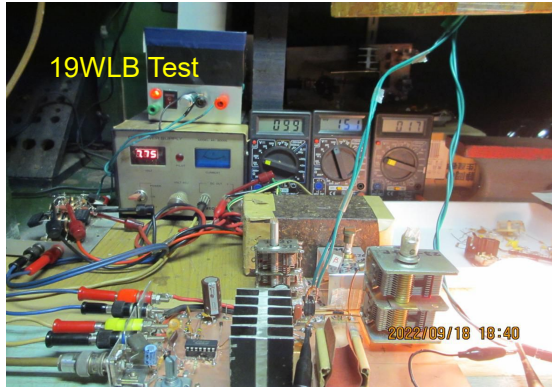

On the SPC:

(1)conductor wire data:

Color Green Thickness (sq) 0.75 Length (m) 100 Number of cores 30 ,

Allowable current (A) 15; Voltage DC12V / 24V;

Wire diameter (Φ mm) 0.18;Coating PVC; Allowable temperature (°C) 80

(coating+wire)outer diameter (Φ mm) 2.3

(2)L2 is wound by clock wise from center,while L1 is counter clock wise.

(3)**Toward Higher Efficiency.**

(a)**0=+E-E**

Energy creation is due to negative energy creation by attraction force field of parallel running current.

Thereby bifilar winding is essential.



Also note it forms both "distributed inductor=L" and "distributed capacitor=C".

Then $\omega L=1/\omega C$ is to generate resonance frequency= ω .

(b)dΩ (t)/dt= k Ω (t) . . .exponential explosion by **positive feedback**

Tornado eddy growing is due to positive feedback generation in Helmholtz eddy equation,

$$D\omega/Dt = (\omega \cdot \nabla)V + \nu \nabla^2 \omega. \quad \langle \omega \equiv \nabla \times V. \dots \text{eddy}, \dots \nabla^2 \omega = -\text{curl curl } \omega + \text{grad}(\text{div } \omega) \rangle.$$

$$= \text{growing term} + \text{attenuation by friction force}(\nu)$$

analogy:center going current forms strong gathering of magnetic field which is to intensify current.

$$\text{curlH} = j + \partial_t D$$

$$k j = \text{curl}(kH) + \partial_t(kD)$$

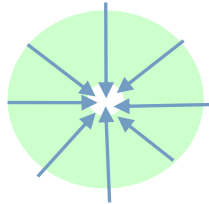

Magnetic field is spin currents alignment.
It is entirely similar with eddy flow down fall in tornado center.
 $\text{curlH} = j$

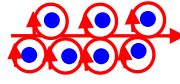

Related Article;

<http://777true.net/The-Saviors-in-Now-Times.pdf>

<http://777true.net/Growing-Electric-Power-by-Tesla-Tornado-Circuit-2.pdf>

This version must be revised.

PS:

Now 2022/9/19,Japan islands is being attacked by strong typhoon #14,authors home is very old and weak,so possible accident would intercept his work ,thereby,he hurried to make this report.

PS2<2022/9/20>:

38W<263Ω>LB_ I/O measurement<2022/9/20>

568kHz($I_{in} = \text{min current}, C_{//} = 2544\text{pF}$) $P_i = 0.120\text{A} \times 265\text{V} = 31.2\text{W}$, $P_o = 38\text{W}$ ($\eta = 1.22$)

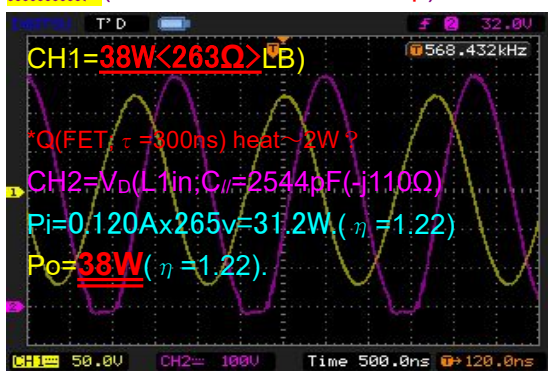

On the substantial efficiency=η*:

CH1=38W<263Ω>LB)

*Q(SW FET; τ =300ns) heat~2W ?

CH2=V_D(L1in;C_{//}=2544pF(-j110Ω)

→ $I_{L1} = 300\text{V}/110\Omega = 2.7\text{A} \rightarrow Q_{L1} = 0.3\Omega(I_{L1})^2/2 \sim 1\text{W}$.

→ $I_{L2} = 141\text{V}/263\Omega = 0.53\text{A} \rightarrow Q_{L2} = 0.8\Omega(I_{L2})^2/2 \sim 0.1\text{W}$

$P_i = 0.120\text{A} \times 265\text{V} - 2\text{W} = 29.2\text{W}?$

$P_o = 38\text{W} + \{0.1\text{W}?, \eta^* = 1.30?\}$

In this 50% up of **38W** measurement,the efficiency(1.22) seems becoming weaker than **26W**(1.27),

However substantial input DC power is lost in **FET heating** due to increasing SW current.

Note the top voltage **600v** of V_D is almost the absolute maximum of 2SK3115,

which intercept increasing output power.Next trial must be exchange FET and L1.

Especially note output power is proportional to (L2 current)².Also input impedance of L1 becomes higher as L2 current becomes larger.

Because L2 current generates **counter current in L1**.This may indicate input power becomes not larger.

*A difficulty is getting **high voltage air varicon**.

☞: Everybody must face the reality of **Climate** and tackle **Energy and Foods Production !!**,

while others are negligible ?!!

[3]:An Evidence that Smaller Output Power Decreases the Efficiency(2022/9/21).

(1) Instead $38W < \eta = 1.22; 263\Omega > LB$, 220Ω resistor was employed in $12W$ efficiency measurement to conclude $\eta = 1.0$ at tuned point for minimum input power. This is not explicit proof that efficiency is increased by increasing output power, however this could be an evidence.

12W < 220Ω > resistor_ I/O measurement < 2022/9/21 >

584kHz ($I_{in} = \text{min current}, C// = 2219pF$) $P_i = 0.073A \times 171v = 12.1W$, $P_o = 12W$ ($\eta = 1.0$)

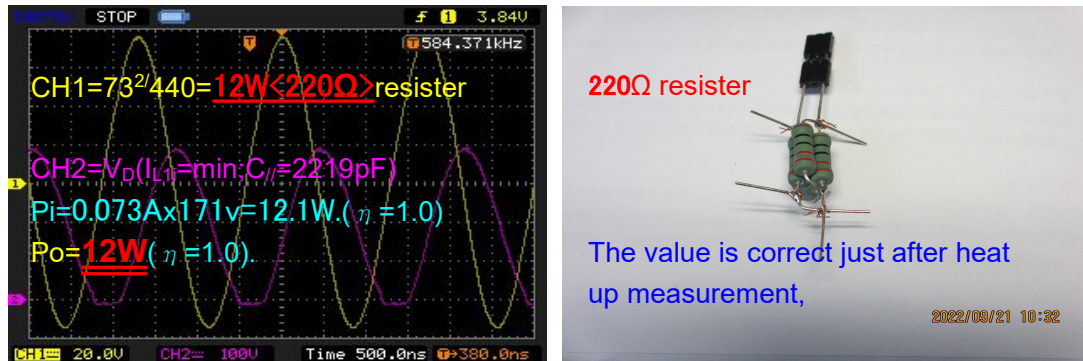

Note; even small power output can exceed $\eta > 1$ in case $R_L \sim 1k\Omega \gg 220\Omega$.

This indicate being of **proper matching impedance of SPC(L2)**, however our concern is larger output of extremely lower impedance ($R_L = \text{load resistor}$).

(2) Multistage Connection of SPCs.

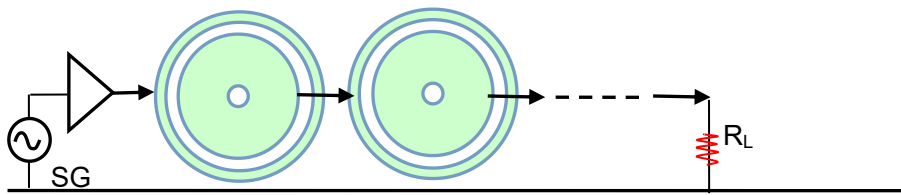

Input and output matching might be solved by multistage connection of SPCs.